

MIGHTY LIFT™ Stainless Steel Pallet Truck

Built to Last!

ML55SS

5,500 lbs Capacity

ML55SS is built with heavy-duty top quality stainless steel to guarantee super performance in tough environment. No more worry about contamination or constant replacement of broken parts. All stainless steel construction meets the extreme sanitary requirement for food, medical and pharmaceutical industries. It assures longer usage in wet, cold and corrosive environment or in the chemical, fishing and meat-processing industries.



- Manufactured & tested to meet ISO 9002 & TUV/GS
- High tensile all stainless steel structure for durability in tough conditions
- Dependable hydraulic pump for quick lifting & smooth lowering
- Adjustable solid push rod for extra support & easy maintenance
- Strong reinforced "C" channel fork for heavy loads
- Sealed stainless steel ball bearing through out
- Extra grease zerks for less wear and tear
- Low temperature hydraulic oil



***Optional
ML55GLV
Hot Dip, Galvanized!***

MIGHTY LIFT™

MIGHTY POWER

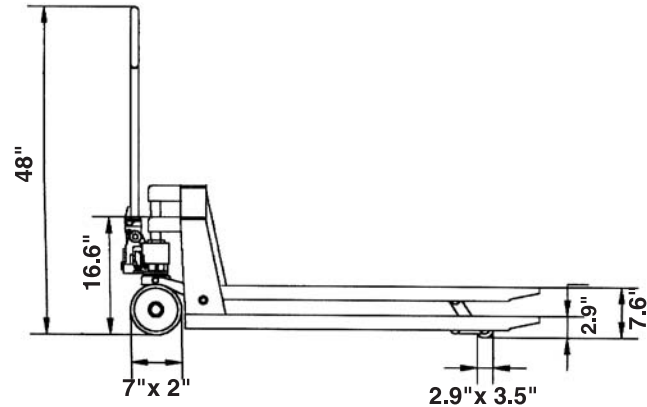
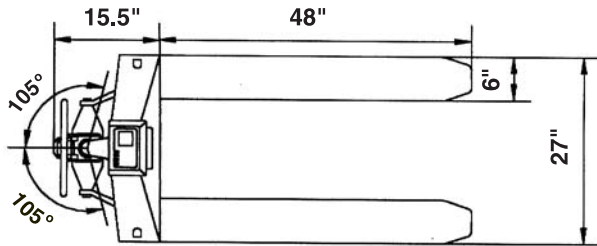

Model No.	Cap. (lbs)	Fork Size WxL	Min. Hgt.	Max. Hgt.	Front Wheel Dia. x W	Steering Wheel Dia. x W	Steering arc	WT (lbs)
ML55SS	5,500	27" x 48"	2.9"	7.6"	2.9" x 3.5"	7" x 2"	210°	184
ML55GLV	5,500	27" x 48"	2.9"	7.6"	2.9" x 3.5"	7" x 2"	210°	208

OTHER PRODUCTS



Skid Adaptor
allows trucks to be used with both pallet & skid
Easy to switch



Load Backrest
for handling high loads
Safe to use



Pallet Truck
with Brake System for total control
Safe & Easy

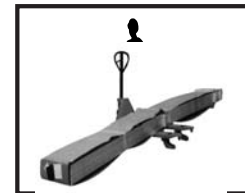

Lateral Pallet Truck
features complete lateral movement in a narrow aisle for extra maneuverability



Highlift Pallet Truck
a pallet truck & a lift-table All in One
Ergonomic & Efficient



Scale Pallet Truck
weighs loads on the spot whenever you want
Simple & Efficient



Hydraulic Lift Table
elevates & transports loads between work stations
Ergonomic & Efficient



Electric & Manual
Stacker for multi-purpose lifting & positioning
Compact & Economic

Mighty Lift warrants hydraulic unit and frame against defective components or workmanship for 1 year. Wheels, axles, bearings, seals are warranted for 90 days. Warranty does not cover usage in cold storage, brine, corrosive, or similar applications unless the product is specially designed for the application. Text of warranty is available on request.

www.mightylift.com

Distributed by: